

# *Quá Trình Và Thiết Bị Lọc Bụi Túi Vải*

# Sơ đồ nguyên lý của quá trình lọc

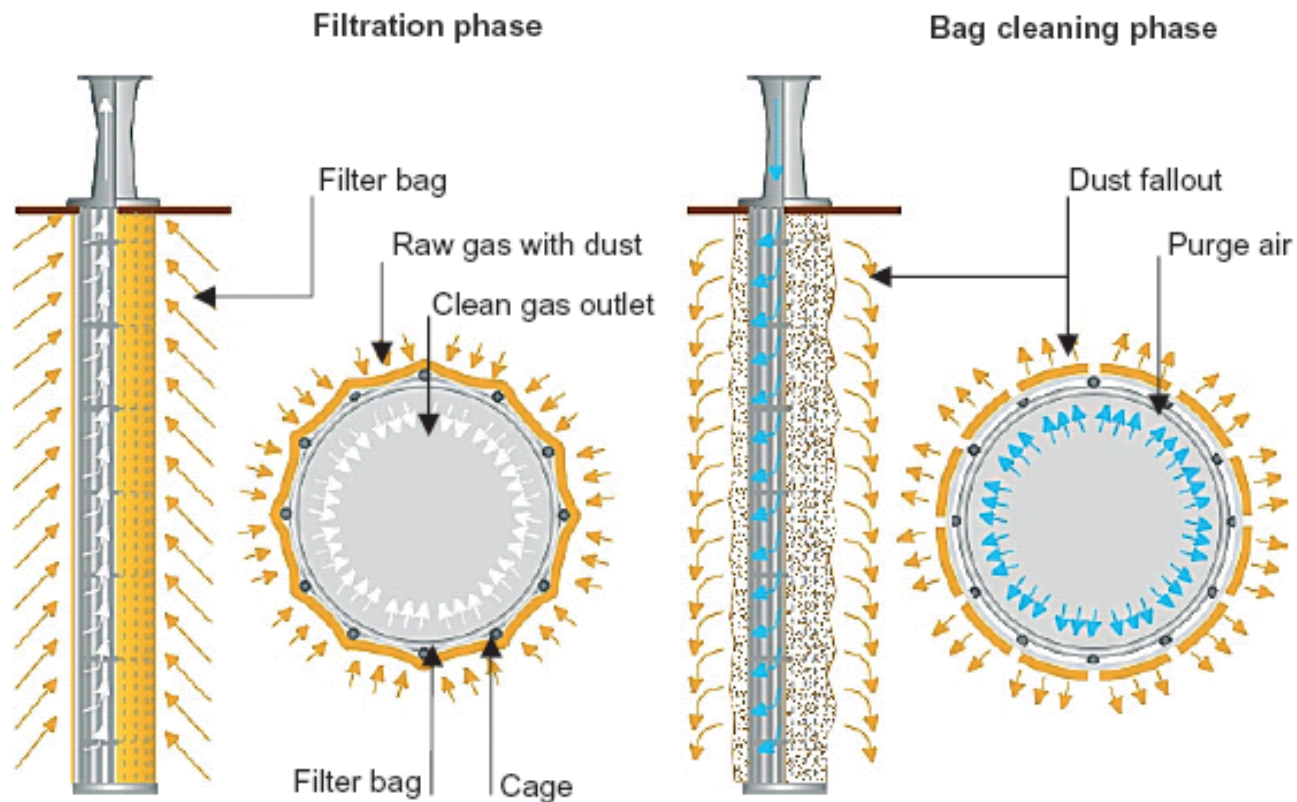

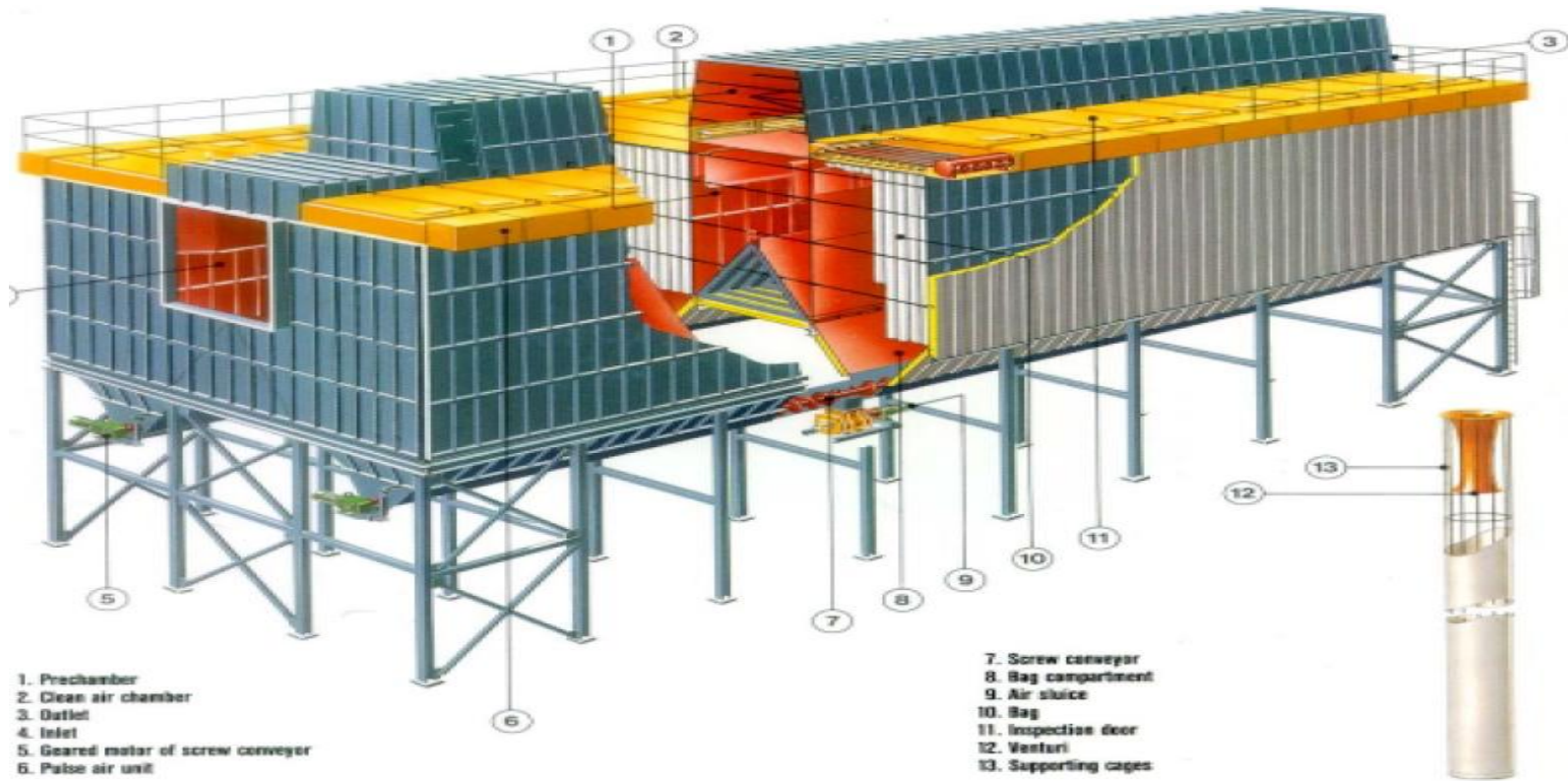

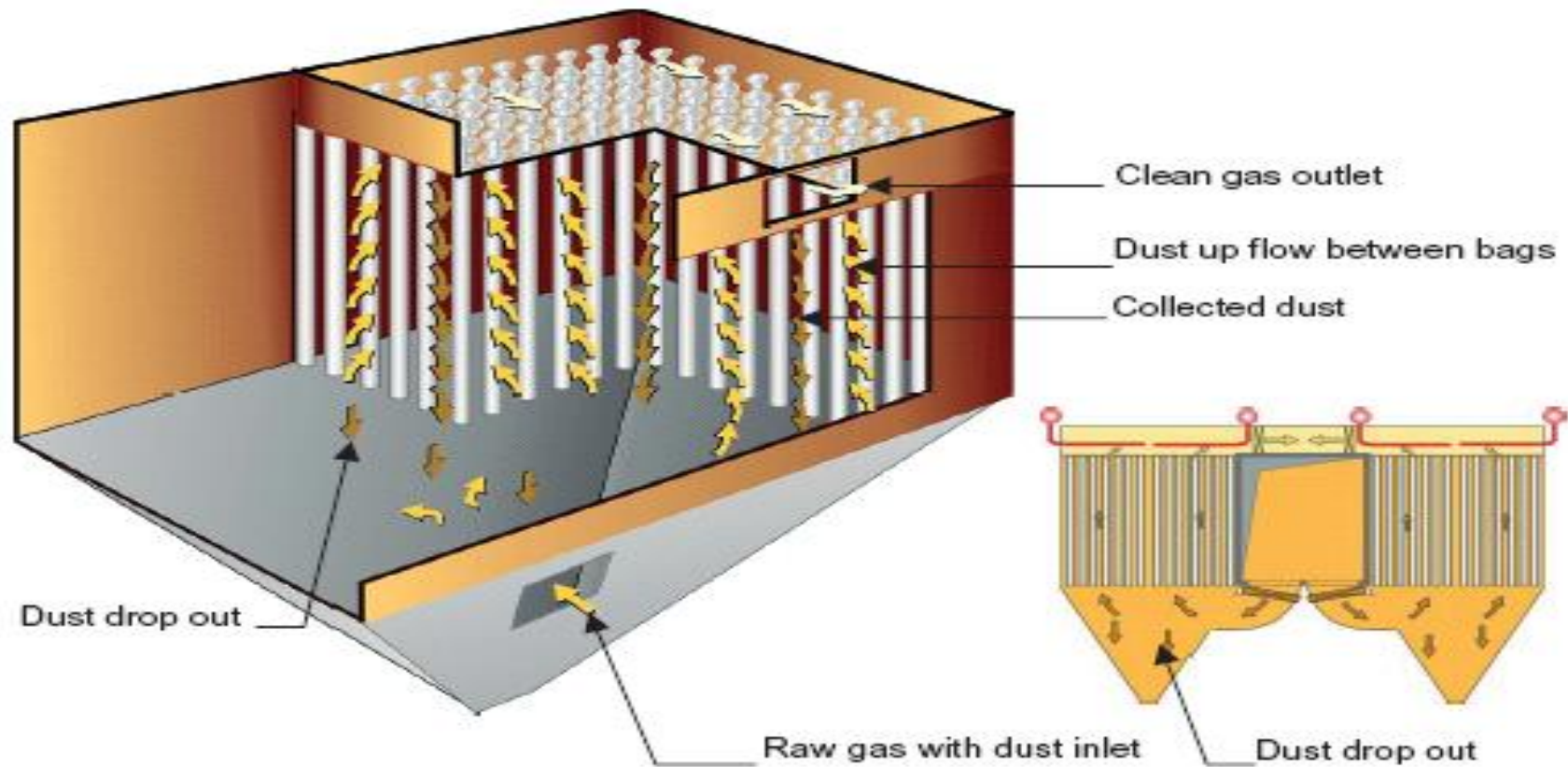

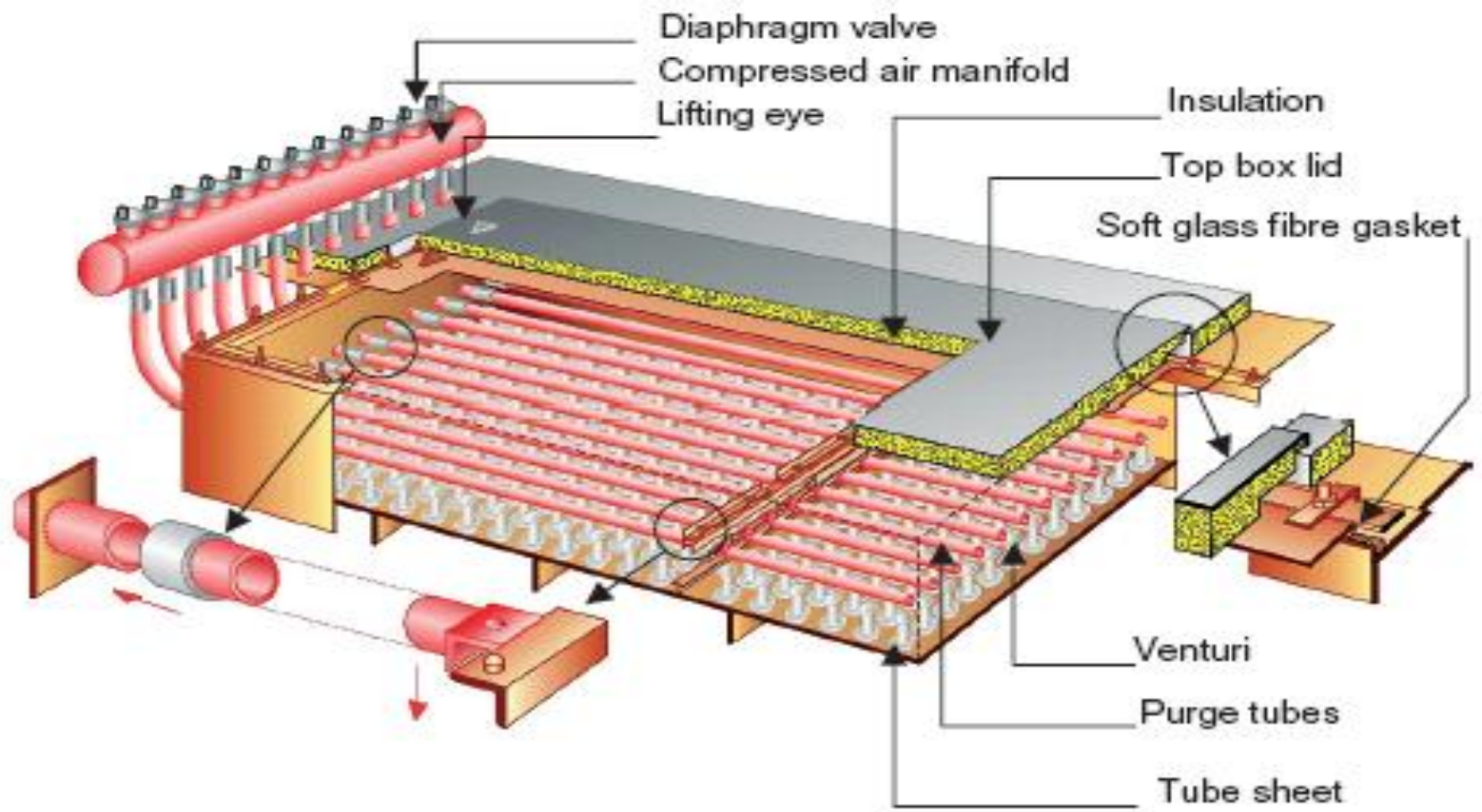



**Single outlet damper**

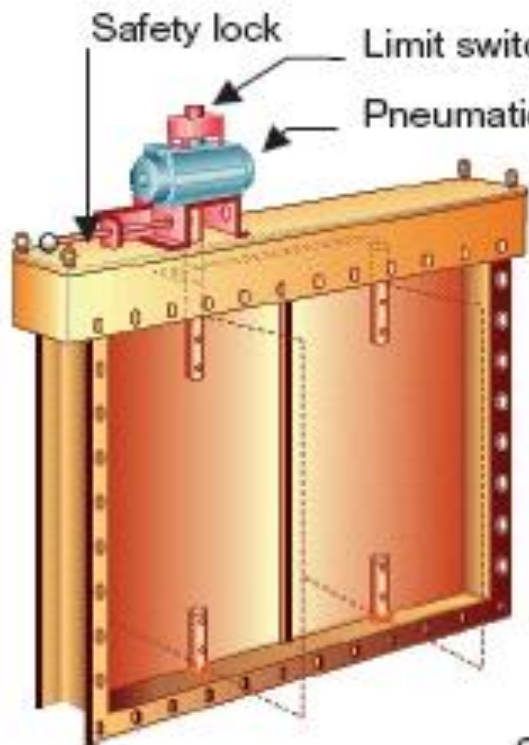

**Double inlet damper**

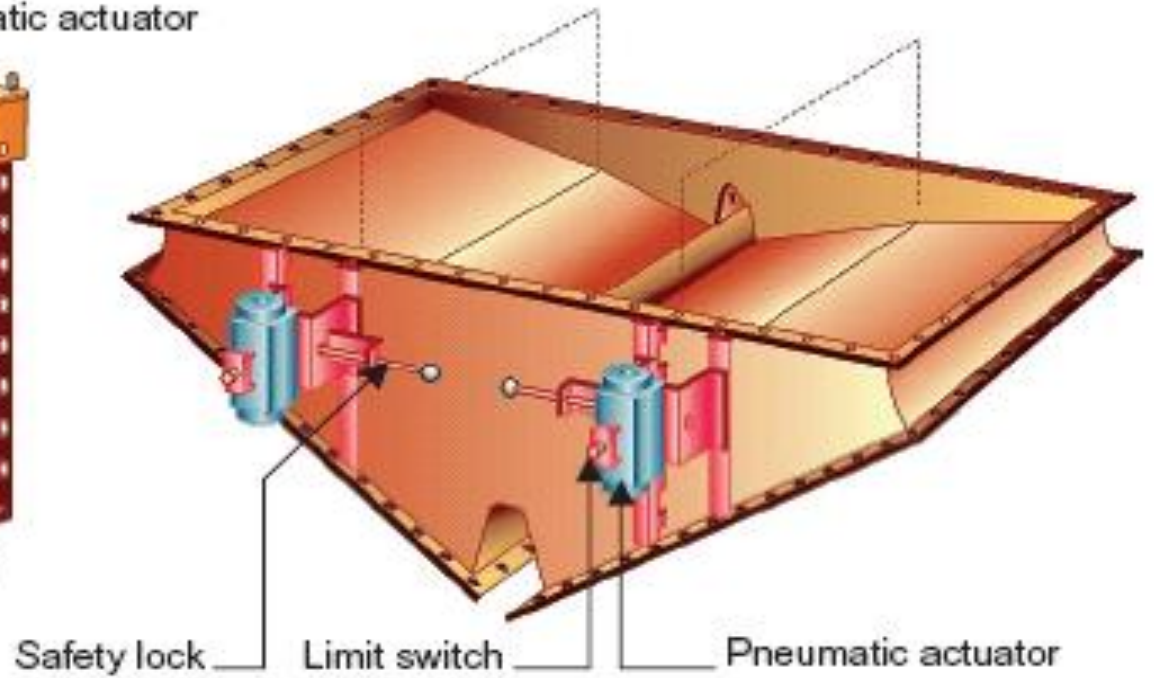

Safety lock  
Limit switch  
Pneumatic actuator

Safety lock  
Limit switch  
Pneumatic actuator

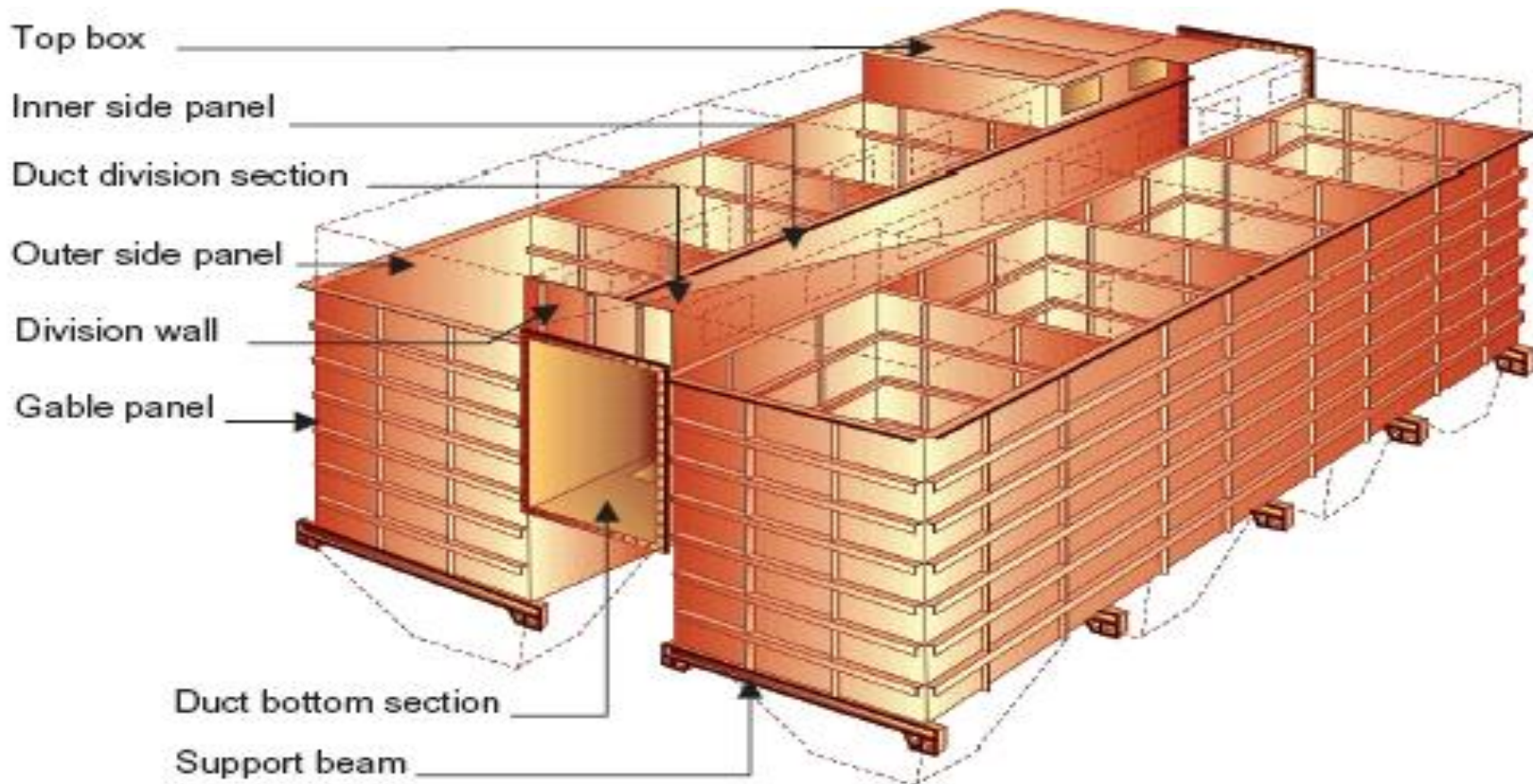

**Casing single type**

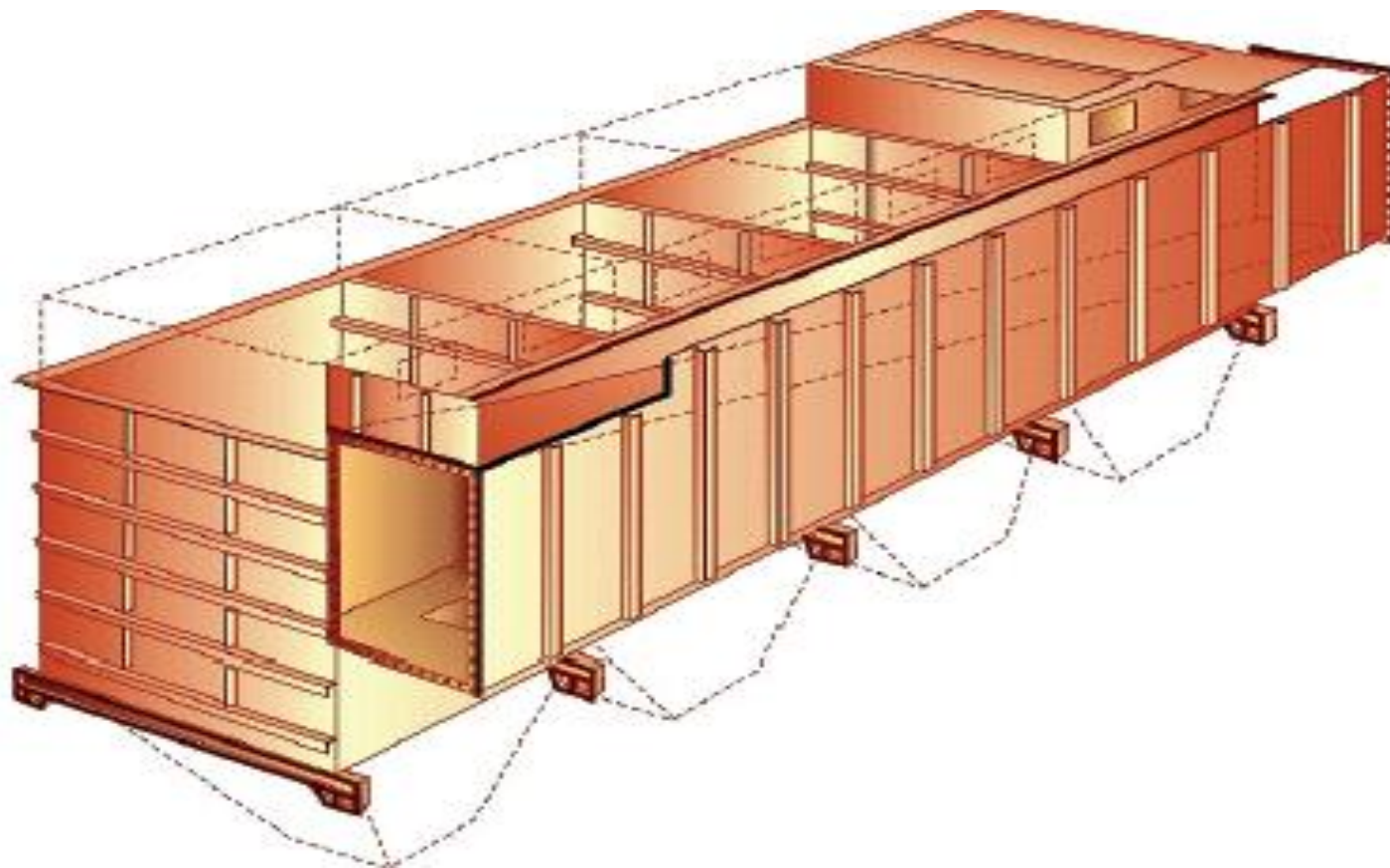



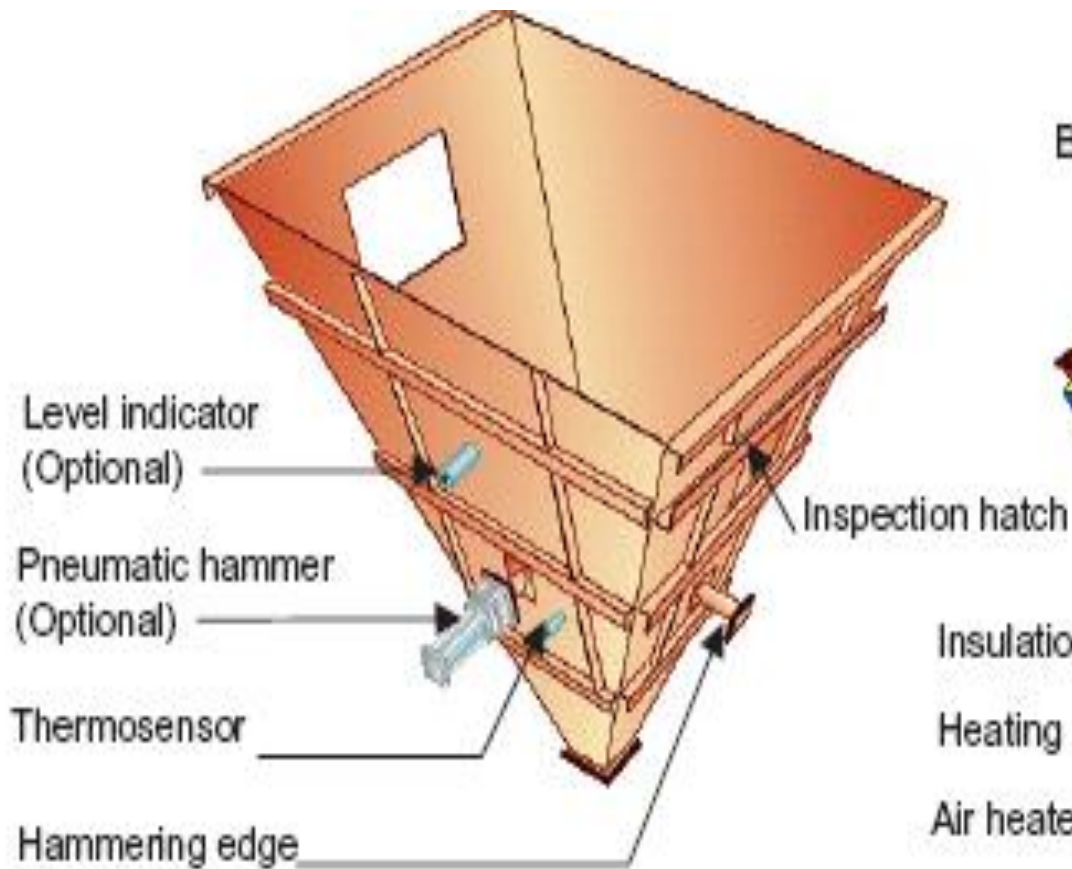

Bottom with heated area (Optional)

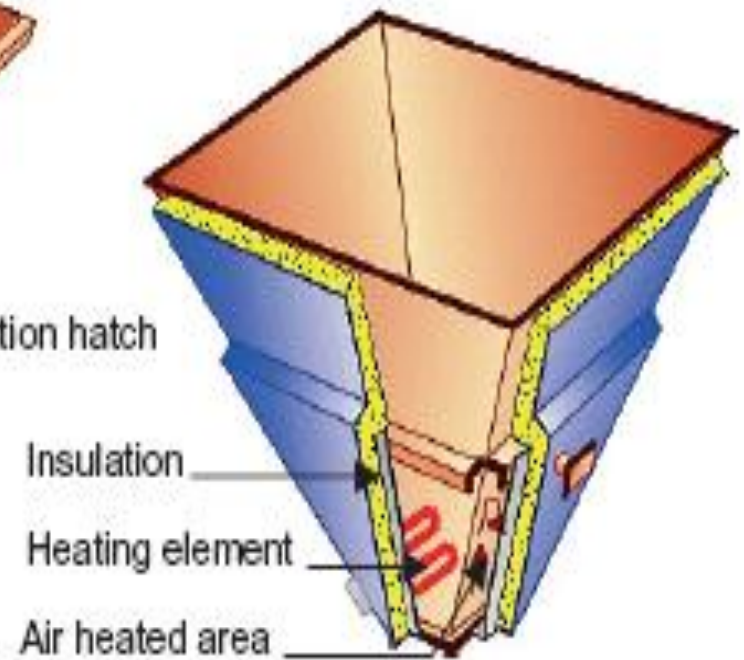

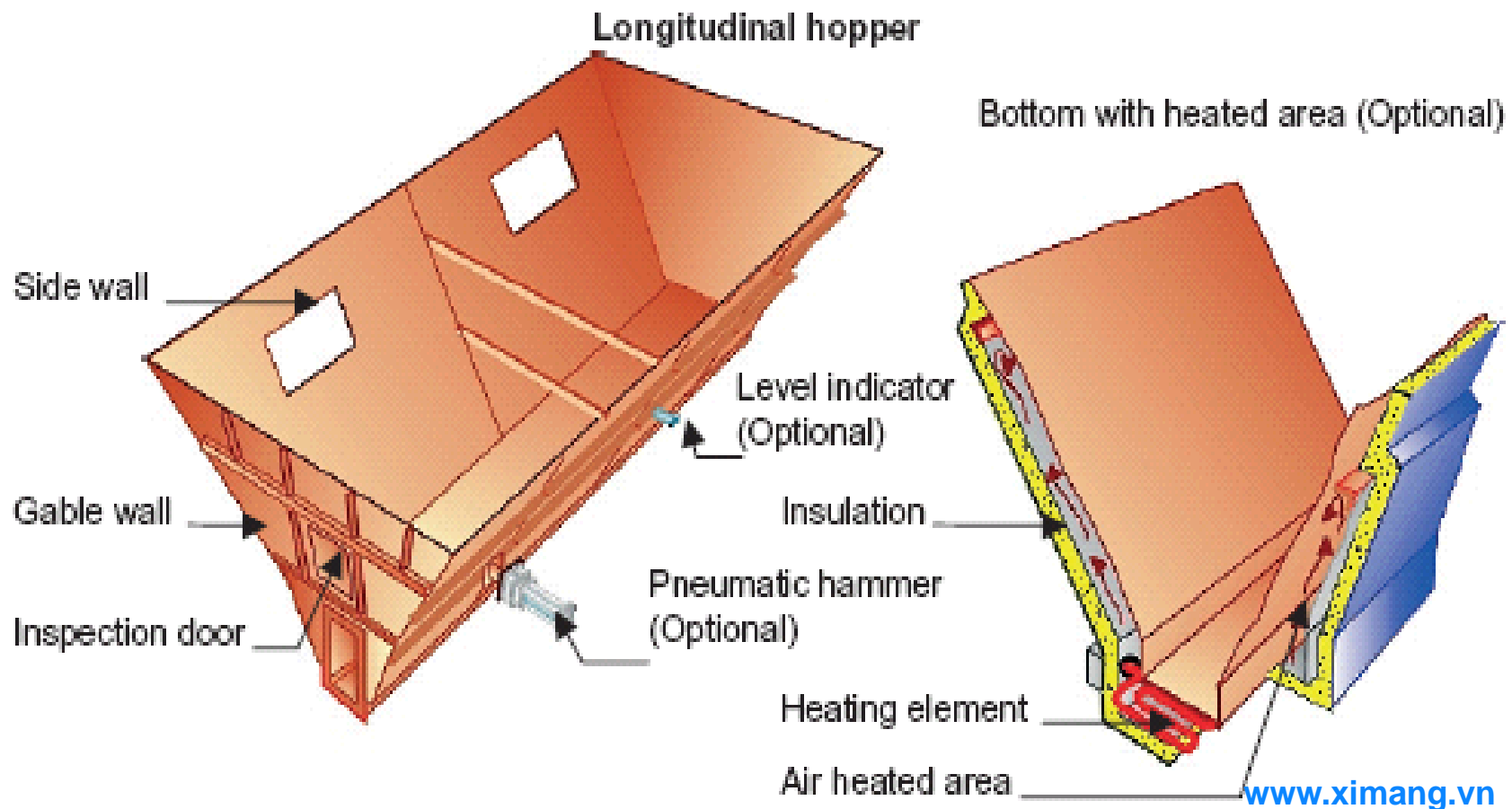

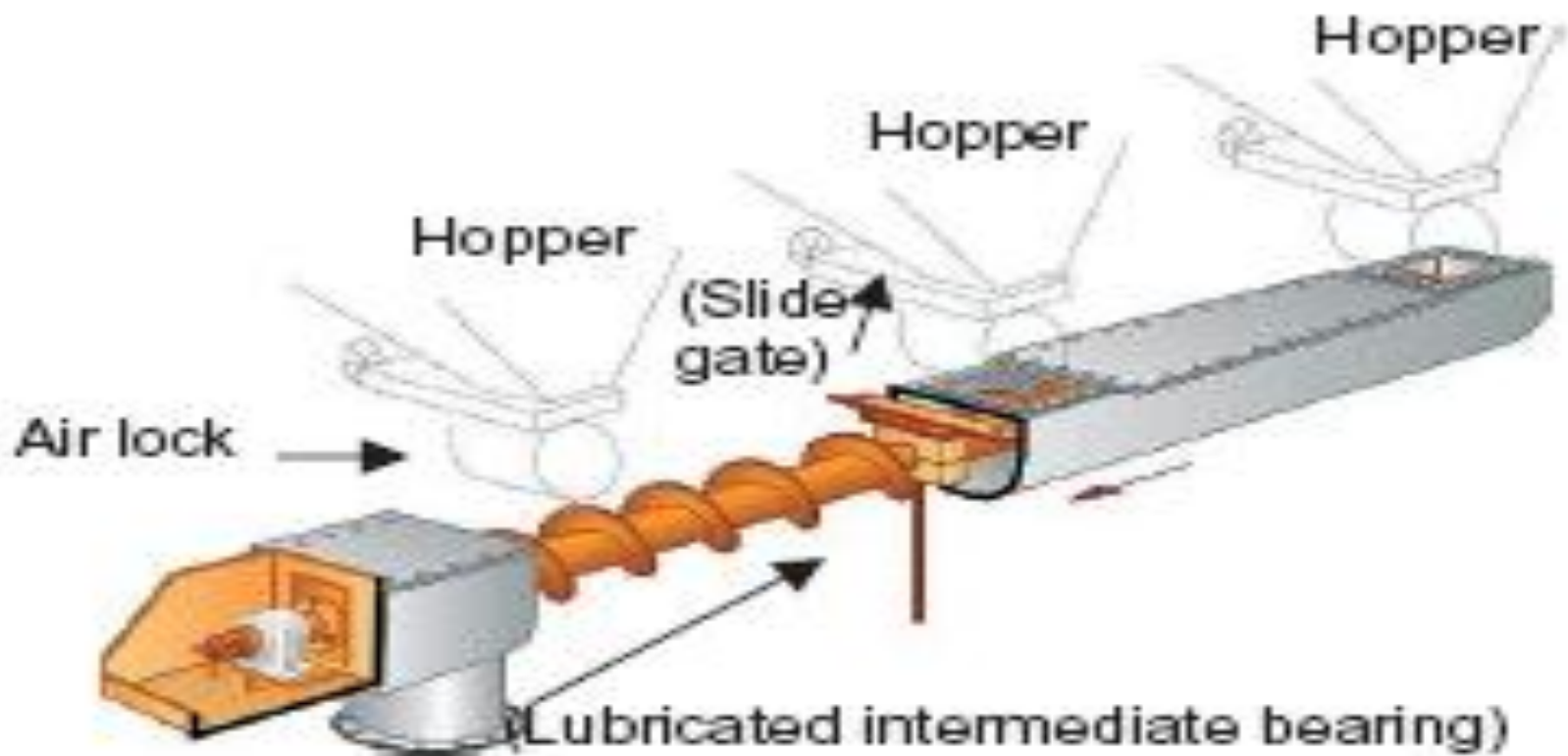

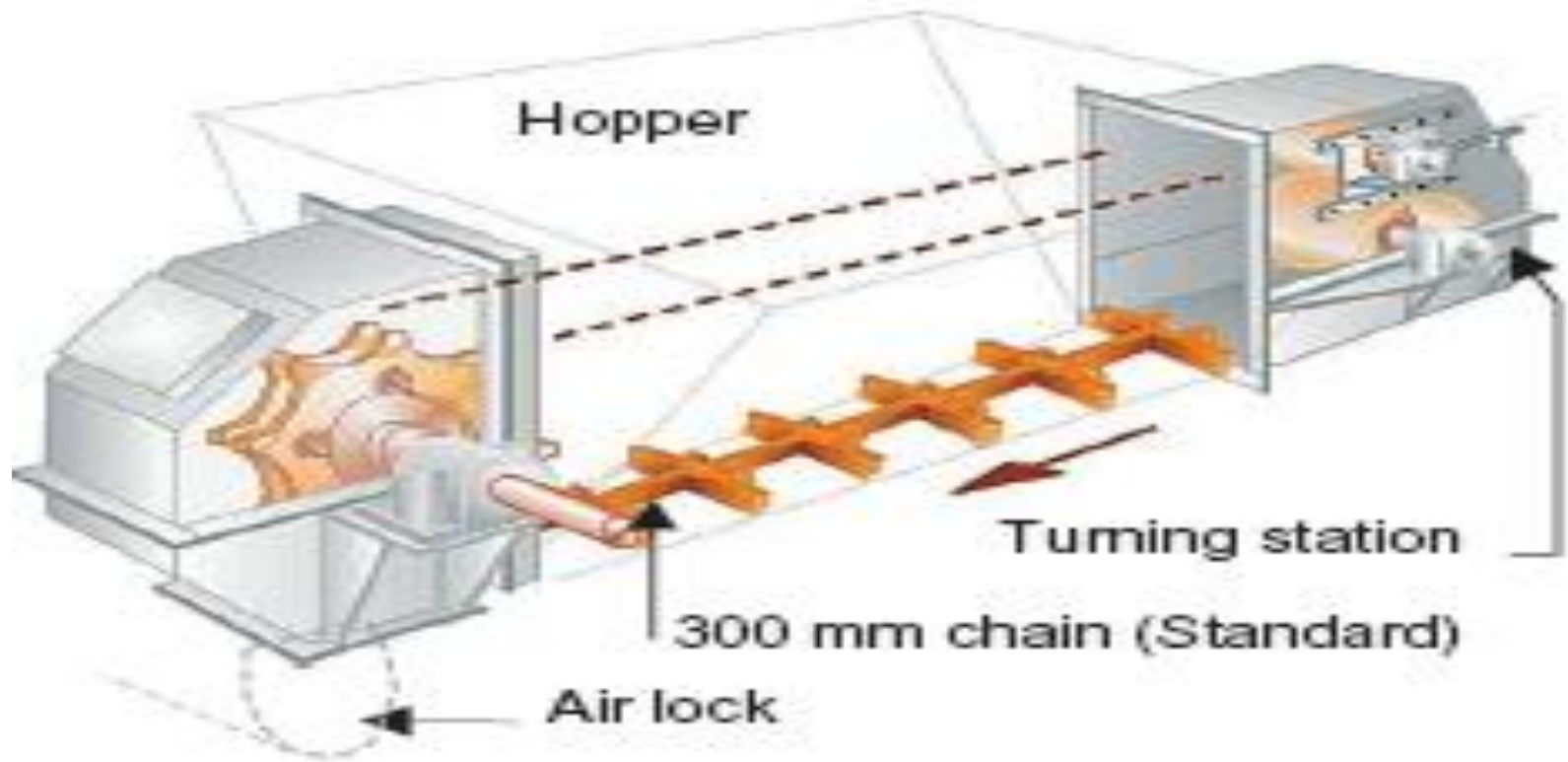



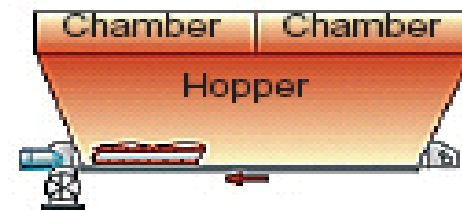
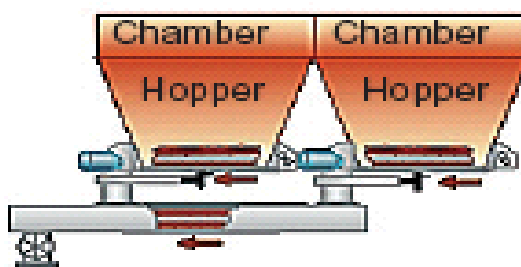
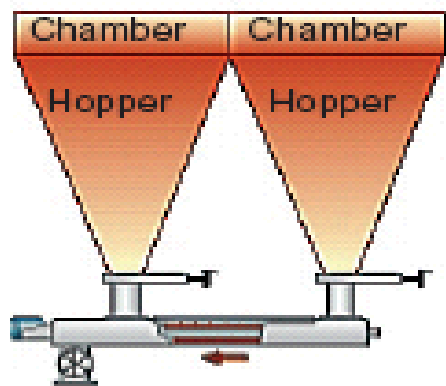
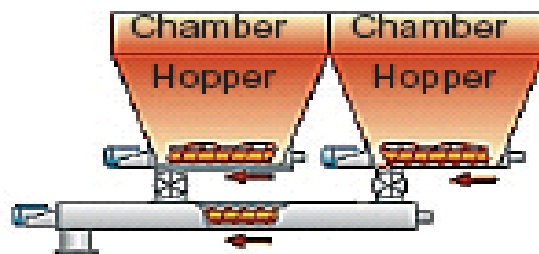
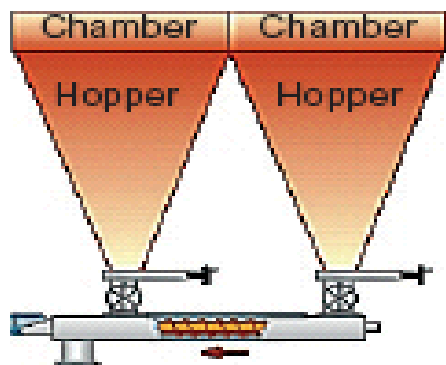





-  Screw conveyor
-  Drag chain
-  Air lock
-  Slide gate

Railings. Horizontal 0.4 kN/m  
Standard. DIN

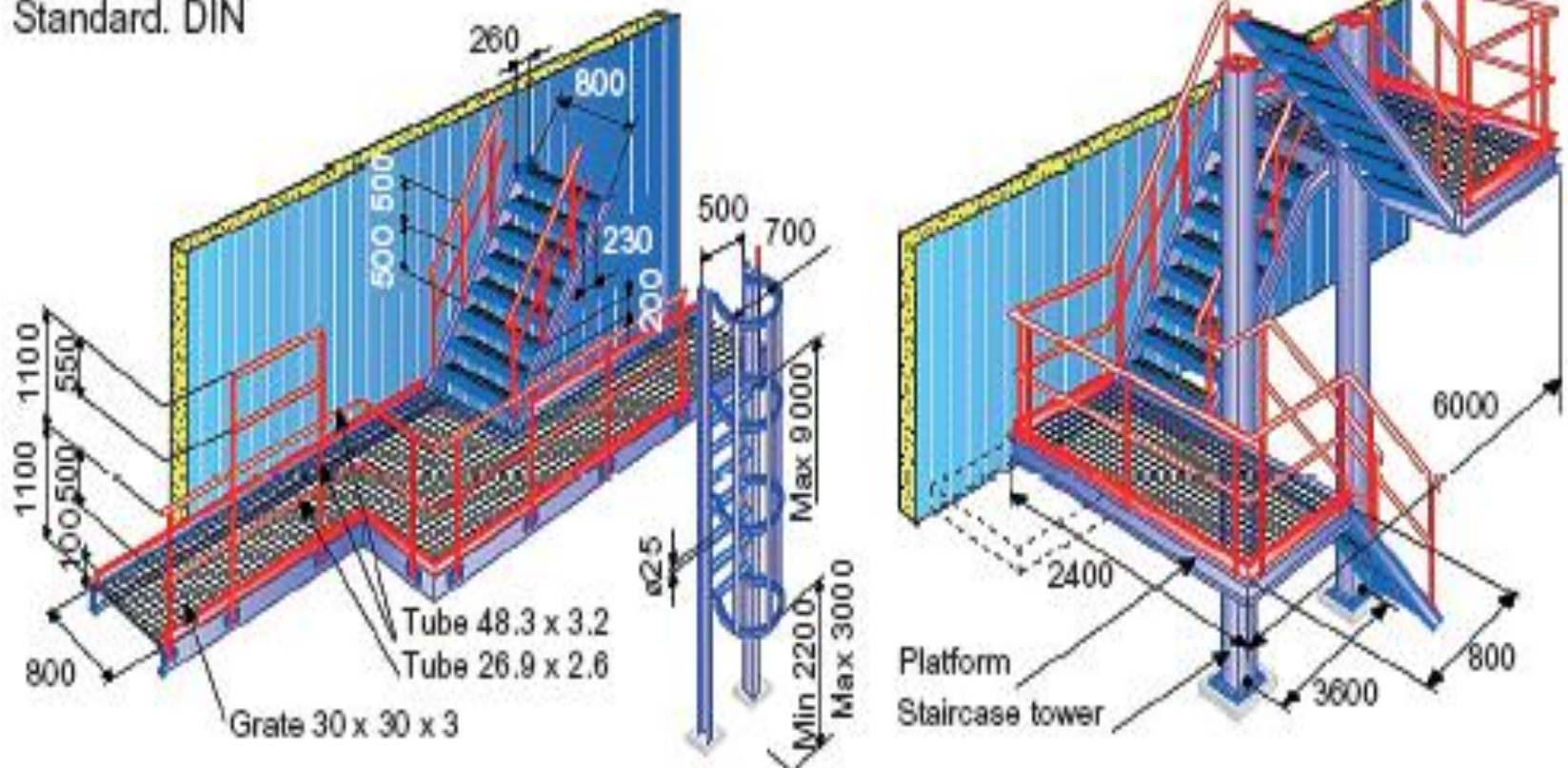

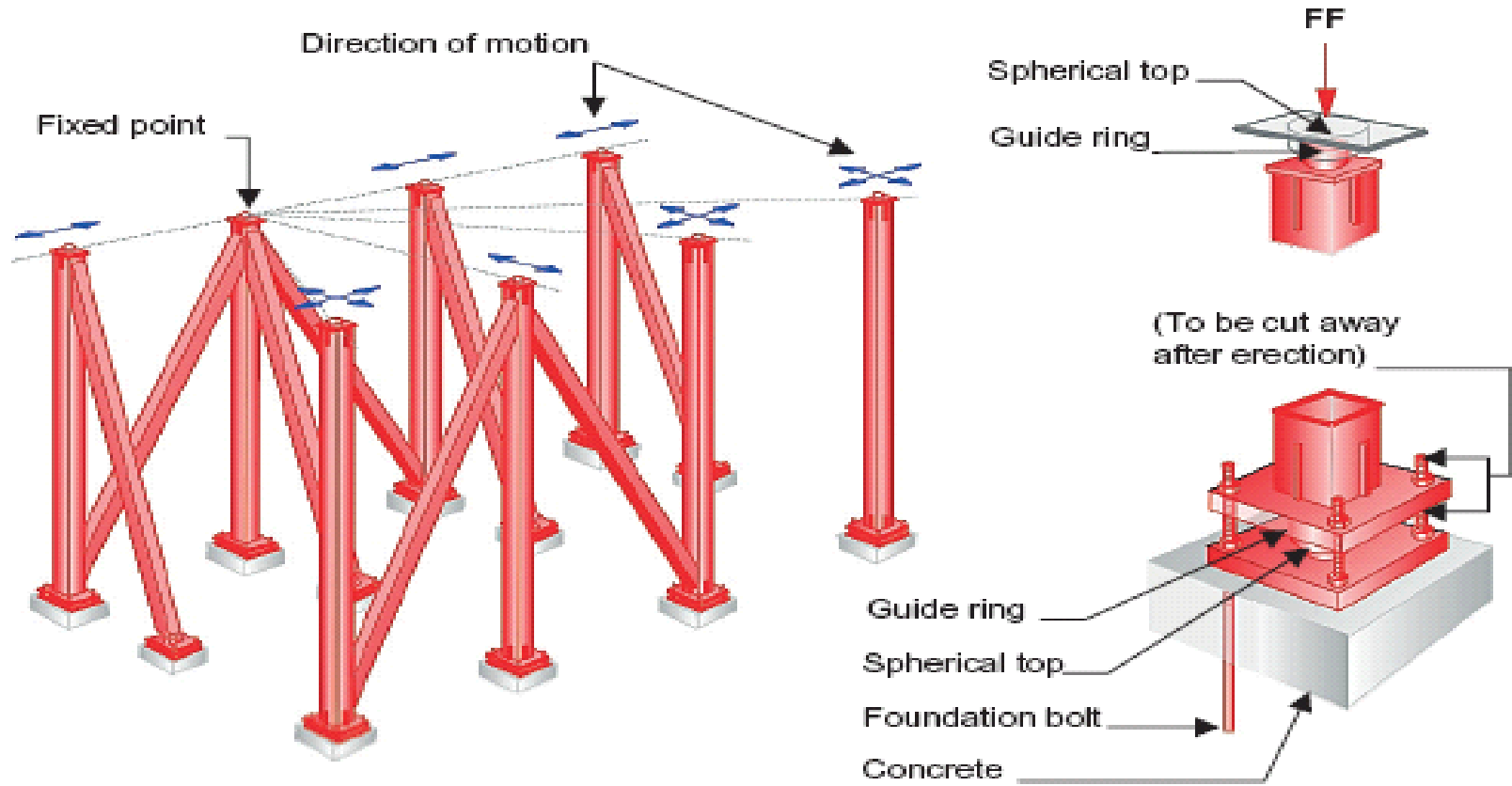

**Roller bearing**

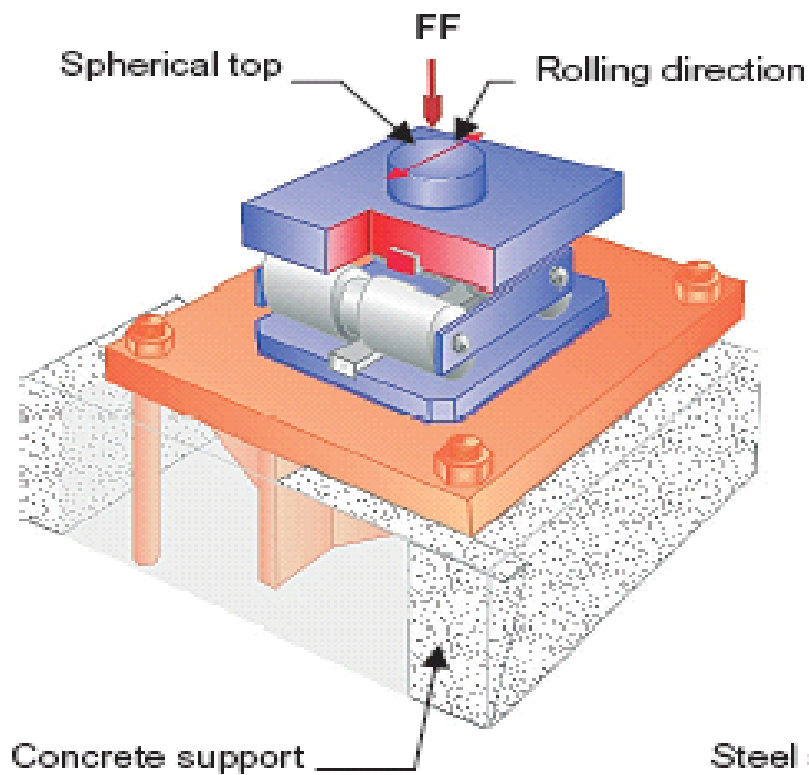

**Slide bearing**

